



# PVC Owner's Manual

Serial Number:

---

## **INTRODUCTION:**

Thank you for selecting and purchasing the NHTPro Passive Volume Control. The PVC was conceived as a direct result of user feedback... as well as needs arising in our own studio work.

Now would be an excellent time to fill out and send in your warranty registration card or register online [www.nhtpro.com](http://www.nhtpro.com). Either method will automatically extend both the parts and labor warranty for an additional two years. If at any time you should require assistance, call our customer service hotline at 800-NHT-9993 (648-9993), or e-mail us at [tech@nhtpro.com](mailto:tech@nhtpro.com).

## **USING THE PVC:**

We think you'll find the PVC a unique product with many potential applications. Here are a few:

- › Level control for mixerless digital audio workstations and non-linear video systems.
- › Level control for pc audio, eliminating the need to use software applettes.
- › Zone level control for distributed audio using multiple amplifiers or active speakers.
- › Level control between modules in guitar rigs
- › Send/return level control in effects loops

## **INSTALLATION:**

The PVC can be used on a desktop, atop other audio equipment, or mounted in a universal 19" EIA rack. Up to three units may be mounted side by side in a single rack space. For desktop or other open-space use, simply plug in your connecting cables and begin using. To rack mount, remove the four feet on the unit's bottom using a #2 Phillips head screwdriver. Do not remove the four rubber pads on the bottom of your PVC which provide proper spacing. Use the included 10-32 screw to attach the bottom of your PVC to your rack tray.

## **WIRING:**

The PVC accepts fully balanced input and output signals. Unbalanced connections may also be made using the supplied RCA-to-1/4" adaptors or custom made cables. If custom cables are required, visit the Tech Help section at [www.nhtpro.com](http://www.nhtpro.com) for wiring and construction diagrams.

Inputs- The combination input jacks accept:

- XLR
- 1/4" TRS balanced (Tip/Ring/Sleeve)
- 1/4" unbalanced
- RCA, using two RCA-to-1/4" adapters included in your PVC package

Outputs- The outputs are female TRS jacks which accept:

- 1/4" TRS balanced (Tip/Ring/Sleeve)
- 1/4" unbalanced
- RCA, using two RCA-to-1/4" adapters included in your PVC package

**WIRING (cont'd):**

The following diagrams show correct wiring for unbalanced and balanced connections.

	1/4"	RCA
Hot (+)	Tip	Tip
Ground & Shield	Sleeve	Sleeve

Unbalanced Input Wiring

	XLR	TRS
Hot (+)	Pin 2	Tip
Cold (-)	Pin 3	Ring
Ground	Pin 1	Sleeve

Balanced Input Wiring

**CONNECTIONS:**

Using and connecting the PVC is very straightforward. Simply insert the PVC in the signal path between the source and the destination as shown in Fig. 1. Remember, the PVC is a passive attenuator and it adds no gain. It only outputs whatever input signal you give it at unity (the same) gain or lower, depending on where you set the front panel output control knob.

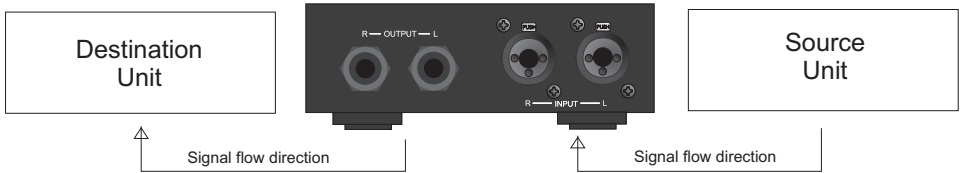

Fig. 1. Signal Flow through the PVC

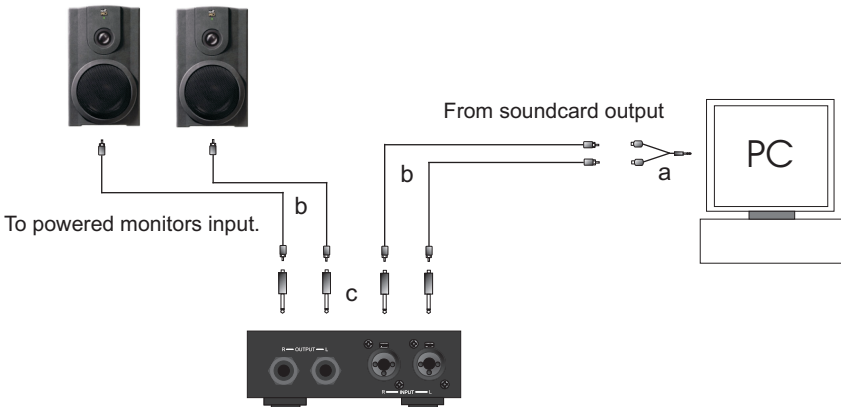

Fig. 2. Typical PC Audio connection. a) 1/8" stereo mini to RCA female (not supplied), b) 2 pairs stereo audio cable - RCA (not supplied), c) RCA - 1/4" adaptors (supplied).

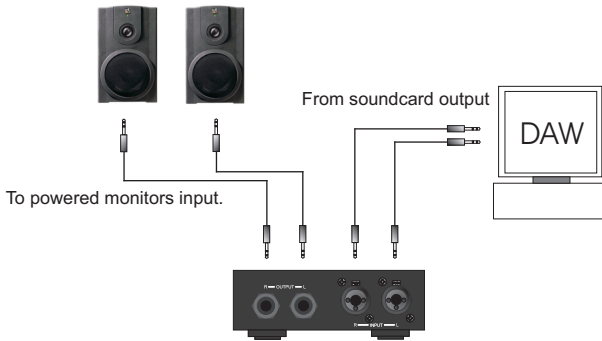

Fig. 3 PVC in Digital Audio Workstation

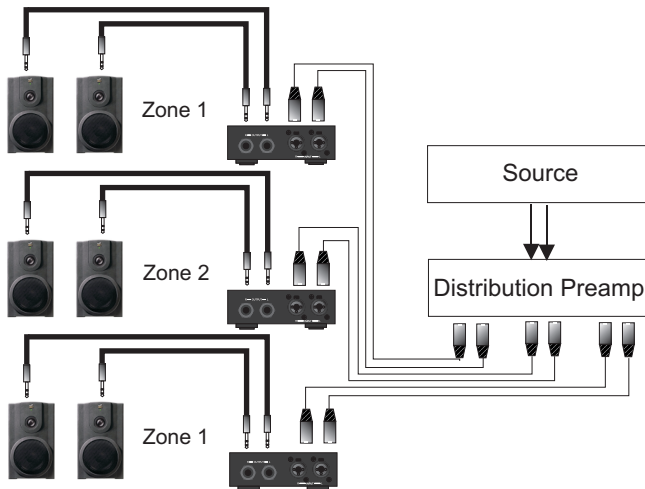

Fig. 4 PVC as a zone controller for Distributed Audio

## TECHNICAL SUPPORT:

Toll free: 800-NHT-9993 (648-9993). Fax: 707-747-1252. Email: tech@nhtpro.com.  
Postal Mail: NHTPro, 6400 Goodyear Rd., Benicia, CA 94510

## SPECIFICATIONS:

Input: Two balanced XLR/TRS combi-jacks. Two 1/4" ~ RCA adaptors included.  
Output: Two balanced TRS. Two 1/4" ~ RCA adaptors included.  
THD/Noise: Unmeasurable.  
Channel Tracking Accuracy: +/- 0.5dB (0 ~60dB).  
Input Impedance: 5 kiloOhms.  
Controls: 1 front panel knob.  
Dimensions/Wt: 1.75"h x 5.5" w x 4.5" d; 1.25 lbs